

|      |          |            |
|------|----------|------------|
| REV. | NOTES    | DATE       |
| A    | RELEASED | 2013.05.02 |

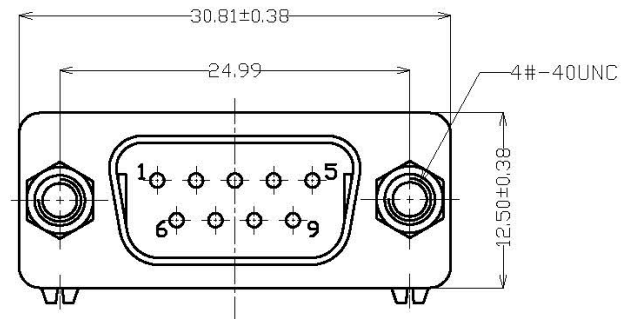

NOTES:

1.MATERIAL

- 1.1 膠芯:PPS UL94V-0,COLOR:BLACK,ROHS
- 1.2 端子:BRASS C2680
- 1.3 鐵殼:SPCC T=0.40mm
- 1.4 魚叉:SPCC T=0.60mm
- 1.5 後蓋:PPS UL94V-0,COLOR:BLACK,ROHS
- 1.6 鉚釘:ZINC(鋅合金)
- 1.7 螺絲:BRASS

2.SPECIFICATION

- 2.1 Current Rate:5.0 Amps MAX
- 2.2 Contact Resistance:30m Ohms Max
- 2.3 Insulator Resistance:1000MΩ Min. at 500V DC
- 2.4 Dielectric Withstrength Voltage: 500V AC R.M.S FOR ONE MINUTE
- 2.5 Operation Temperature:-55°C to +105°C
- 2.6 MAXPROCESSING TEMP:260±5°C FOR 30 SECONDS

"\*" 標示是重點管控尺寸

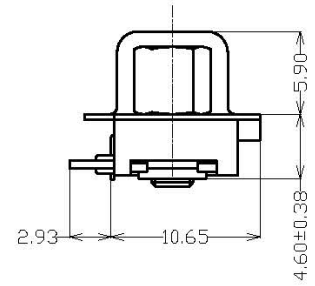
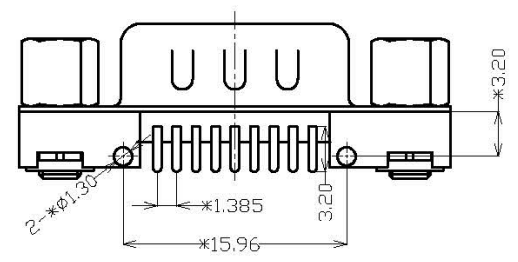

|                |                 |       |
|----------------|-----------------|-------|
| PART NO.       | PLATING         | COLOR |
| A02+0912-2021T | GOLD/TIN PLATED | BLACK |

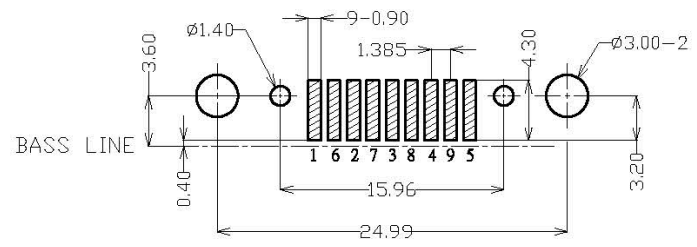

P.C.B. LAYOUT(TOLERANCE±0.05)  
TOP VIEW

|                      |
|----------------------|
| DIMENSIONS TOLERANCE |
| METRIC               |
| .0= ±.38             |
| .00= ±.25            |
| .000= ±.15           |
| .0000= ±.            |
| ANG.= ± 2°           |

|            |          |
|------------|----------|
| 單位(UNITS)  | mm       |
| 數量(QTY)    | N/A      |
| 材料(MTL)    | SEE NOTE |
| 處理(FINISH) | SEE NOTE |

|           |  |
|-----------|--|
| 繪圖(DRAW)  |  |
| 設計(DE'N)  |  |
| 審核(CH'K)  |  |
| 核准(APP'D) |  |

|  |          |                  |          |
|--|----------|------------------|----------|
| <b>鉍創科技有限公司</b><br>TRONTEK TECHNOLOGY CO.,LTD. |          |                  |          |
| 圖名(NAME)                                       |          |                  |          |
| D-SUB 9公2.0超薄型貼板式叉鉚鎖 RoHS                      |          |                  |          |
| 料號(PART NUMBER)                                |          | A02+0912-2021T   |          |
| 圖號(DRAW NUMBER)                                |          | RA0209122021T    |          |
| 圖檔(FILE NAME .DWG)                             |          |                  |          |
| 圖檔(SCALE)                                      |          | E:GCT/A/02/091/5 |          |
| 比例(SCALE)                                      | 圖紙(SIZE) | 頁次(SUBET)        | 版次(REV.) |
| 1/1  | A4       | 1                | A        |