

- NOTES:
- MATERIAL:
 - HOUSING: HIGH TEMPERATURE THERMOPLASTIC UL 94V-0 RATED, BLACK
 - CONTACT: COPPER ALLOY
 - SHELL: COPPER ALLOY/SPCC
 - PLATING:
 - CONTACT: GOLD PLATED OVER NICKEL
 - SHELL: NICKEL PLATED
 - P/N: HHF-33X001-XSB
- TERMINAL PLATING CODE: _____ REV. CODE _____
- A: CONTACT AREA: GOLD FLASH
 B: CONTACT AREA: MATTE TIN 100u"
 C: CONTACT AREA: MATTE TIN 100u"
 SOLDER AREA: MATTE TIN 100u"
 SOLDER AREA: MATTE TIN 100u"
- PACKING CODE
 1: TARY+Cover
 2: TUBE REEL+Cover
 3: TUBE+Cover

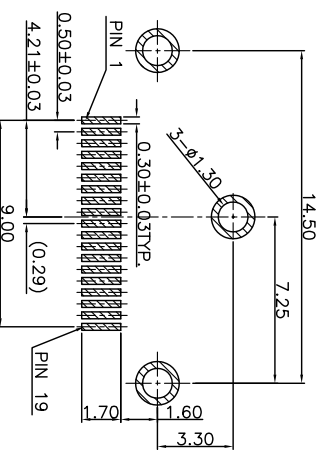

RECOMMENDED PCB LAYOUT THICKNESS = 1.6 mm
TOLERANCE = ±0.05
(TOP VIEW)

MATERIAL		TOLERANCE UNSPECIFIED									
FINISH		0.0 ±0.30		0"		±T		NAME		SHEET	
DRAWN		0.00 ±0.20		.0"		±T		HDH1 A/F 朝天式 SMT TYPE (无外壳)		1/2	
DESIGNER		0.000 ±0.10		.0"		±0.5°		CHU		REV	
CHECKED								CHU		A	
APPROVED								11/03/02			
DRAWN								11/03/02			
DESIGNER								HUO			
CHECKED								HUO			
APPROVED								HUO			

Rev. 版本	CHANGE DESCRIPTION 变更内容	REVISOR 制/修/切人	DATE 日期
A	新版发行	chu	2011-03-02

鉅創科技有限公司
 TRONTEK TECHNOLOGY CO., LTD.

SCALE 1:1 UNIT mm

F
E
D
C
B
A

1 2 3 4 5 6 7 8