

RECOMMENDED PCB LAYOUT(TOP VIEW)
GENERAL TOLERANCES:±0.05

NOTES:

1. MATERIAL:
 - 1.1 HOUSING: THERMOPLASTIC FLAMMABILITY RATING UL94V-0
 - 1.2 CONTACT: COPPERY ALLOY T=0.15mm
 - 1.3 SHELL: STAINLESS STEEL T=0.25mm
2. FINISH:
 - 2.1 CONTACT:
 - 3u"Min.Au PLATED ON CONTACT AREA
 - G/F PLATING ON SOLDER TAIL AREA
 - 50~80u" NICKEL UNDERPLATING OVERALL
 - 2.2 SHELL:
 - 80~120 u" MATT TIN PLATING ALL
 - 50~80u" NICKEL UNDERPLATING OVERALL
3. SPECIFICATION:
 - 3.1 CURRENT RATING: 0.5A(2.3.4CONTACT)/1.8A(1.5CONTACT) MAX.
 - 3.2 VOLTAGE: 30 VAC
 - 3.3 TEMPERATURE RANGE: -30 °C ~ 85 °C
 - 3.4 CONTACT RESISTANCE: 30 MILLIONHM MAX.
 - 3.5 DIELECTRIC WITHSTANDING VOLTAGE: 250 VAC r.m.s
 - 3.6 INSULATION RESISTANCE: 100 MEGOHMS MIN

鉸創科技有限公司
TRONTEK TECHNOLOGY CO.,LTD.

TOLERANCE: XX ±0.30 XXX ±0.25 XXXX ±0.15 X° ±2° X.X° ±0.5°	DRAWN BY :	DATE :	PART NAME:
	ANDY	2016-3-24	MICRO USB 7.15 TYPE 加固定
	CHECKED BY:	DATE :	PART NO.
	FRANK	2016-3-24	TMC03-USBD05-715
UNIT: mm [inch]	APPROVED BY:	DATE :	MOLD NO.
SCALE:1:1 SIZE: A4	DAVID	2016-3-24	
			DRAW NO.
			SHEET NO.

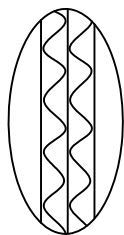
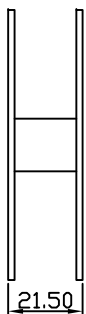
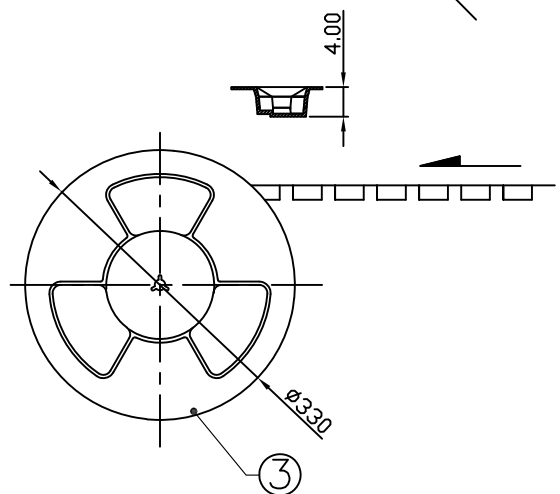
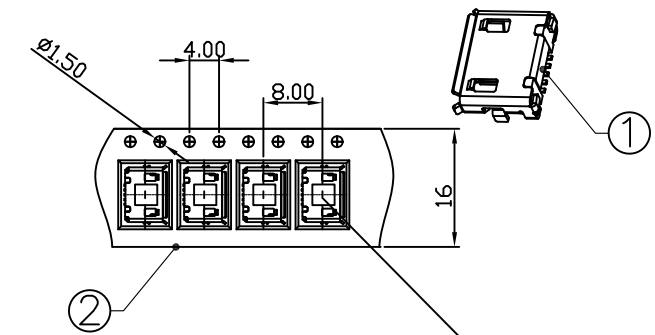

紙箱材質
B=B

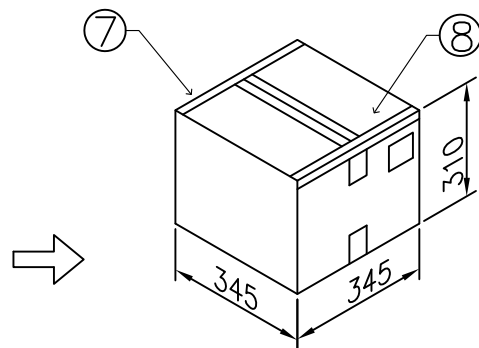
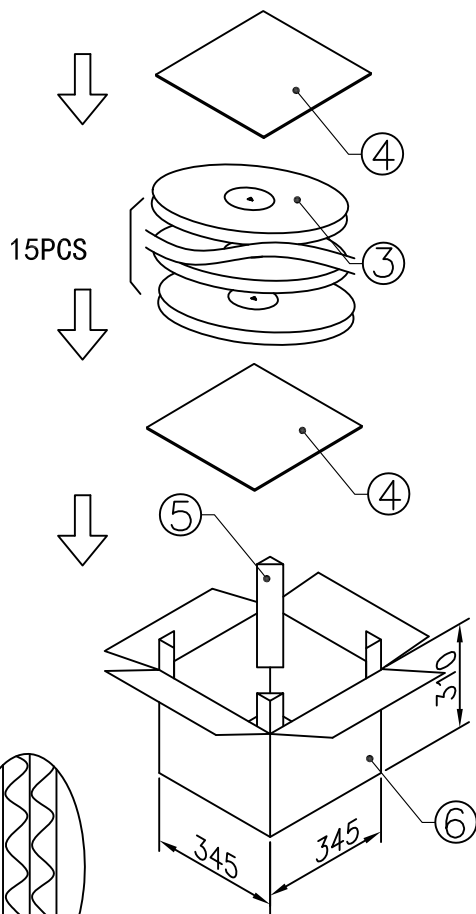

序号	物料名称	规格	物料用量
1	产品		2000PCS/盘
2	载带	16X8	16.6M/盘
3	胶盘	330X330X21.5	15PCS/箱
4	纸板	340X340X0.50	2PCS/箱
5	纸柱	85X90X80X310	4PCS/箱
6	纸箱	340X340X320	40PCS/板
7	透明胶纸		包装时定
8	标签		1PCS/箱
9	护条		包装时定
10	编织带		包装时定
11	栈板	1000X1000	1PCS/板

备注: 1. 每箱重:*Kg 2. 栈板: 10.56Kg 3. 载带前后留38PCS空格

鉸創科技有限公司 TRONTEK TECHNOLOGY CO., LTD.			
TOLERANCE: XX ±0.30 XXX ±0.25 XXXX ±0.15 X* ±2* XX* ±0.5*	DRAWN BY : ANDY	DATE : 2016-3-24	PART NAME: MICRO USB 7.15 TYPE 加固定
	CHECKED BY: FRANK	DATE : 2016-3-24	PART NO.: TMC03-USBD05-715
UNIT: mm [inch] SCALE:1:1 SIZE: A4	APPROVED BY: DAVID	DATE : 2016-3-24	PART NO.: MOLD NO.: DRAW NO.: SHEET NO.: