

REV.	ECN NO.	LOCATIONS.	DESCRIPTION	DATE	CHANGER

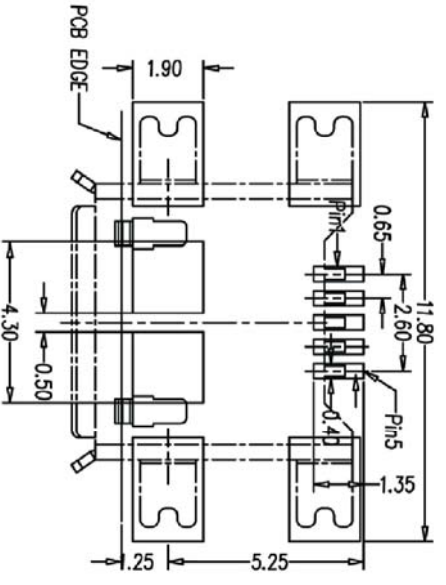
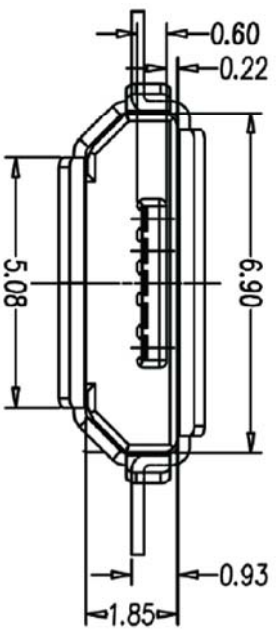
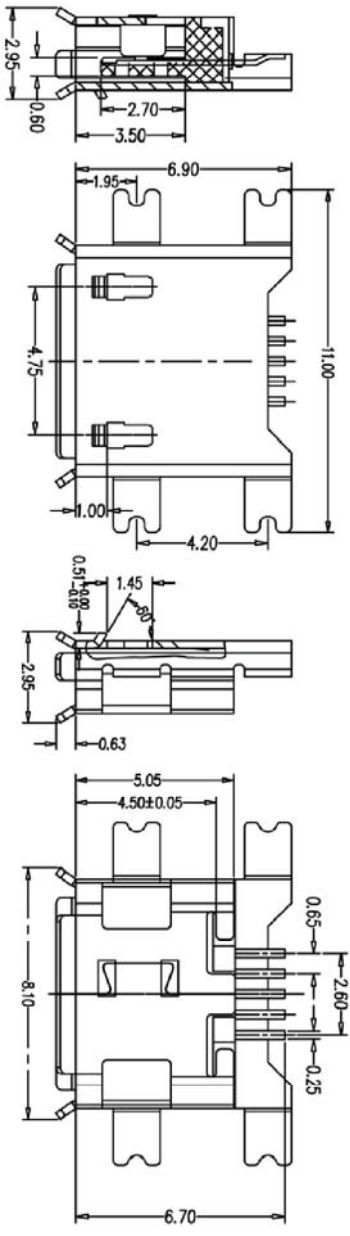
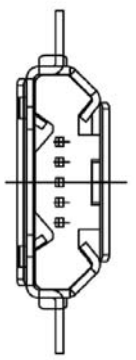

- Note:
1. Material:
- 1.1 Housing: High temperature thermoplastic with g.f. UL94V-0
  - 1.2 Contact: copper alloy, t=0.20mm
  - 1.3 Shell: copper alloy, t=0.25mm
2. Specification:
- 2.1 Current rating: 1 A Max.
  - 2.2 Dielectric withstanding voltage: 100 V(ac) for 1 min.
  - 2.3 Contact resistance: 50 mΩ Max.
  - 2.4 Insulation resistance: 100 MΩ Min.
  - 2.5 Total mating force: 3.57 Kgf Max.
  - 2.6 Total unmating force: 1.0 Kgf Min. 0.81~2.05 Kgf Min. after 10000 insertion/extraction cycles
  - 2.7 Temperature range: -30°C~80°C

GENERAL TOLERANCE		TITLE:	
X± 0.20	X*± 2°	Micro USB 5f B-TYPE(沉板式) SMT	
X± 0.15	X*± 0.5°	PART NO.	
XX± 0.10	XX*±	TMU-02-07-D-12	
XXX± 0.05	XXX*±	DWG NO.	

CUSTOMER DRAWING		SCALE:	
APPROVED	CHECKED:	1:1	SHEET: 1 / 1
tony	tony	1:1	B

鉸創科技有限公司  
TRONTEK TECHNOLOGY CO., LTD.

20120418